

# RAC-120

## High Speed Tri-Seal Carton Closer



where products meet packaging™

Featuring flexible design and a compact footprint, the ADCO RAC-120 high speed tri-seal carton closer was designed with your needs in mind. With its precision servo-powered 90-degree transfer, the RAC-120 can seal a wide variety of carton shapes and sizes at speeds up to 120 cycles per minute. ADCO's time-tested lugged carton transfer system with powered overhead and flexible grippers maintain positive control of the carton all the way through the closing and sealing operation. This reliable and simple to operate tri-seal carton closer is ideal for the most demanding production environments. Like all ADCO machines, the RAC-120 is constructed in stainless steel and is available in standard or washdown configurations.

### Benefits

- Stainless steel construction improves cleanability and eliminates corrosion
- Positive, continuous motion lugged carton transfer maximizes control and reliability
- Fast, "no-tool" changeover improves productivity and reduces downtime
- Large carton size range protects your investment as products change
- Advanced guard design keeps operators safe and maximizes maintenance access

# RAC-120 High Speed Tri-Seal Carton Closer

## Product Features

- Stainless steel construction
- Speeds up to 120 cartons per minute
- Accepts cartons randomly or back-to-back
- Servo-driven 90-degree transfer system
- Compact frame with leveling feet and casters
- Lugged carton transfer system
- Nordson® ProBlue hot melt glue system
- Allen-Bradley® PLC control package
- Category 3 safety system with a fully-interlocked barrier guard package
- Many options available upon request

## Typical Applications

- Snack foods
- Flow-wrapped products
- Frozen foods
- Ready meals
- Dairy products
- Baked goods

## Utilities

### Electrical

230/460 VAC, 3-Phase with ground (PE), 60 Hz

### Air Consumption

10 CFM @ 70 PSI



## PLAN VIEW

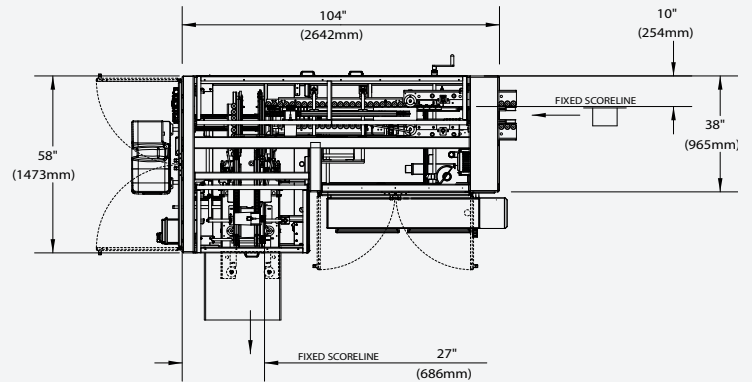

## SIDE ELEVATION

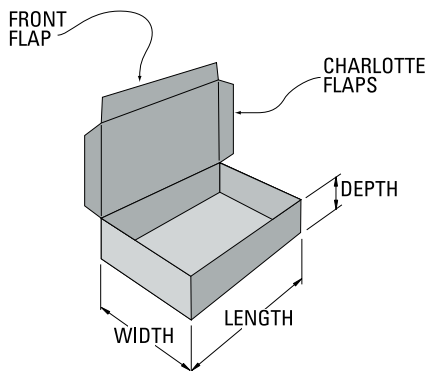
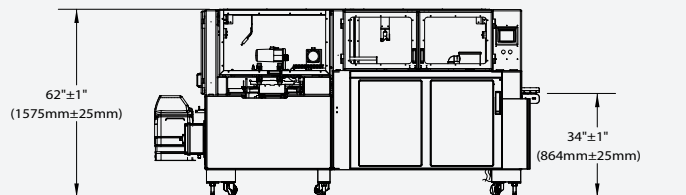

## CARTON SIZE RANGE

Dimensions	(in)		(mm)	
	Min	Max	Min	Max
Length	4	14	100	355
Width	3	12	75	305
Depth	1	5	25	125

Not all minimums and maximums apply.  
Special modifications are available to extend the size range.



For more information on this product, scan the QR code with your mobile device.