

# HCF

## Top Load Carton Former

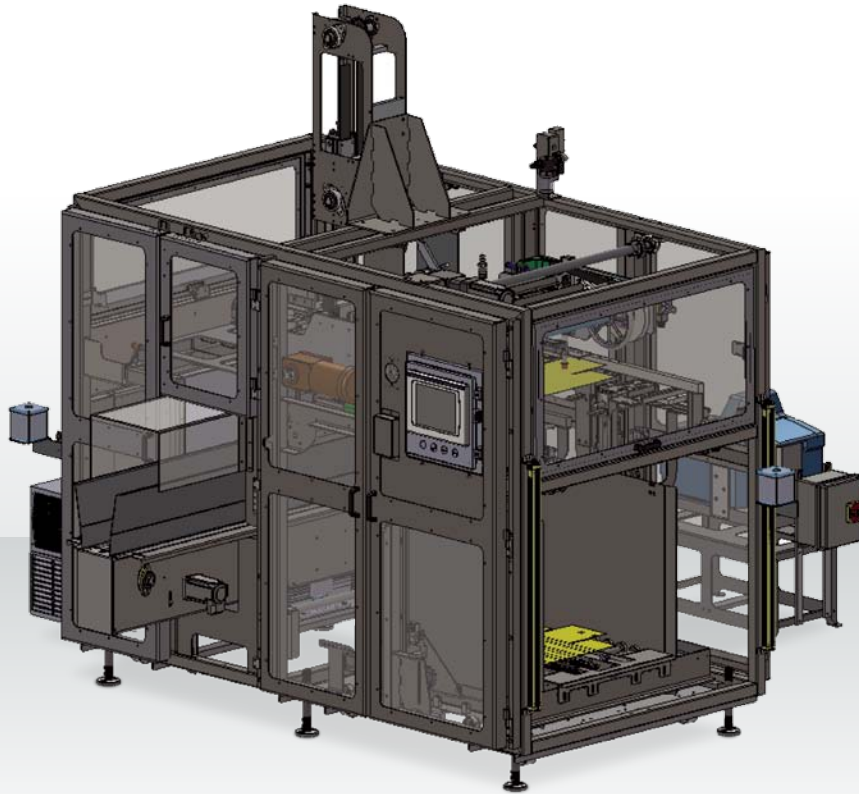

where products meet packaging™

Designed to form large tri-seal paperboard cartons as well as corrugated cartons at speeds up to 50 cycles per minute, the versatile ADCO HCF top load carton former features a unique top pick carton feed system that significantly reduces the problems associated with material variations and warped board. The reliable HCF also features a positive powered feed belt system to feed carton blanks into a servo-controlled forming cavity, optimizing machine control and speed. With its heavy duty welded frame and drive system, the HCF is built to withstand the rigors of the most demanding production environments. Ideal for Retail Ready applications, the flexible HCF features quick change forming heads and an ergonomically friendly, easy-to-load magazine. Like all ADCO machines, the HCF is constructed in stainless steel and is available in standard or washdown configurations.

### Benefits

- Stainless steel construction improves cleanability and eliminates corrosion
- Heavy-duty construction reduces maintenance and maximizes uptime.
- Fast, easy changeover reduces downtime and increases productivity
- Servo-controlled forming section optimizes machine performance and consistency
- Top pick carton feed system improves machinability of warped board and saves money
- Easy integration to other ADCO top load machinery saves time and money
- Advanced guard design keeps operators safe and maximizes maintenance access

# HCF Top Load Carton Former

## Product Features

- Stainless steel construction
- Variable speed drive up to 50 cycles per minute
- Capable of forming both, paperboard cartons and corrugated trays
- Top pick carton feed system
- Servo-controlled forming mandrel
- Powered feed belts
- Overload detent system for jam protection
- Shuttle style carton transfer system
- Capable of forming lock or glue style cartons and trays
- Nordson® ProBlue hot melt glue system with pattern control (when glue is specified)
- Allen-Bradley® control package with touch screen HMI interface
- Category 3 safety system with fully-interlocked barrier guard package
- PackML programming
- Leveling feet and casters
- Many options available upon request



## PLAN VIEW

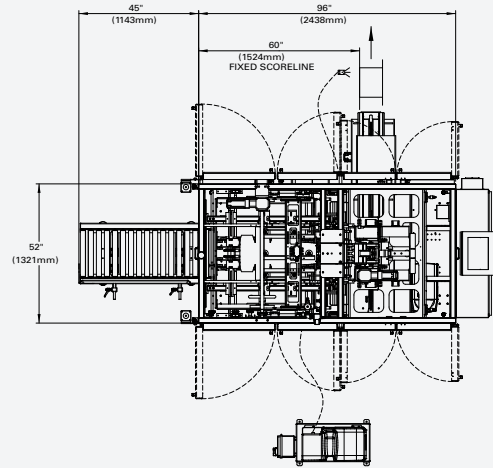

## SIDE ELEVATION

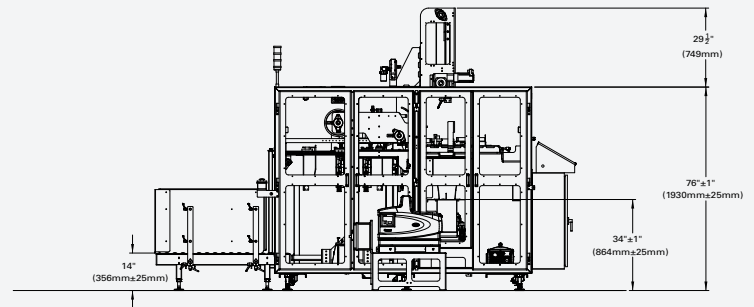

## Typical Applications

- Retail Ready/Display Ready packaging
- Frozen Foods
- Baked goods
- Snack Foods
- Club store packaging
- Beverage
- Dairy
- Flow-wrapped products

## Utilities

### Electrical

230/460 VAC, 3-Phase with ground (PE), 60 Hz

### Air Consumption

10 CFM @ 95 PSI

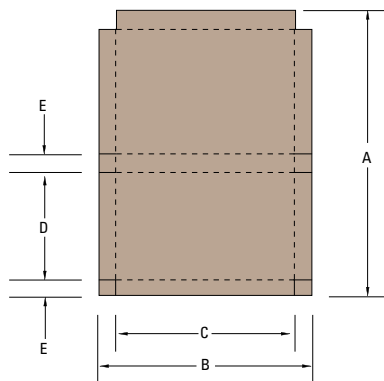

## CARTON SIZE RANGE

Dimensions	(in)	
	Min	Max
A	14"	36"
B	10"	28"
C	6"	16"
D	4"	15"
E	2"	6"

Not all minimums and maximums apply. Special modifications are available to extend the size range.



For more information on this product, scan the QR code with your mobile device.