

BBC/SBBC

Balcony Barrel Cam Cartoner

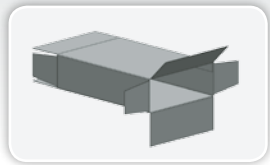
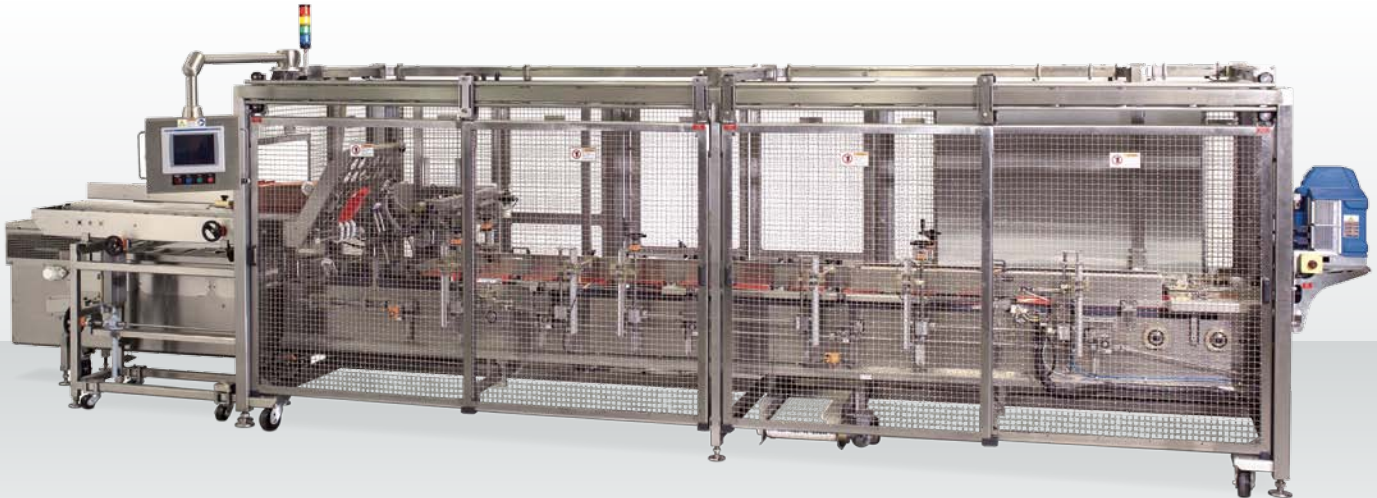

where products meet packaging™

Featuring open “balcony” design, the ADCO BBC horizontal end load cartoner and its compact sibling, the SBBC, are the best choice for today’s toughest sanitary production environments. Offering maximum cleanability and access by design, the BBC family of cartoners are capable of erecting, loading and sealing a wide range of end load carton sizes and styles at speeds up to 400 cycles per minute. Simple operation, fast changeover, ergonomic design and standard PackML programming, ensure maximum output with minimal operator input. Like all ADCO machines, the BBC family of cartoners are constructed in stainless steel and are available in standard or washdown configurations.

Benefits

- Sanitary ‘balcony’ design maximizes cleanability and machine access
- Stainless steel construction improves cleanability and eliminates corrosion
- Flexible and adaptable design protects your investment as products change
- Rotary carton feeder with optional orbital feeder and pre-break ensures smooth, efficient operation
- Easy to load magazine reduces operator fatigue and increases run time
- Compact design saves on space and improves portability
- Advanced guard design keeps operators safe and maximizes maintenance access

BBC/SBBC - Balcony Barrel Cam Cartoner

Product Features

- Stainless steel construction
- Sanitary balcony frame design
- Rotary carton feeder with optional orbital feeder and pre-break
- Easy to load, high capacity magazine
- Product infeed conveyor with adjustable buckets
- Capable of erecting, loading and sealing either tablock style or glued cartons
- Nordson® ProBlue hot melt glue system (when glue is specified)
- Allen-Bradley® PLC control system with touch screen HMI
- PackML Programming
- Category 3 safety system with a fully-interlocked barrier guard package
- Many options, including multi-axis servo control available upon request



Typical Applications

- Frozen Pizza
- Bag-in-box
- Ready meals
- Flow-wrapped products
- Frozen Entrees
- Baked goods

Utilities

Electrical

230/460 VAC, 3-Phase with ground (PE), 60 Hz

Air Consumption

2-3 CFM @ 65-70 PSI

PLAN VIEW - BBC

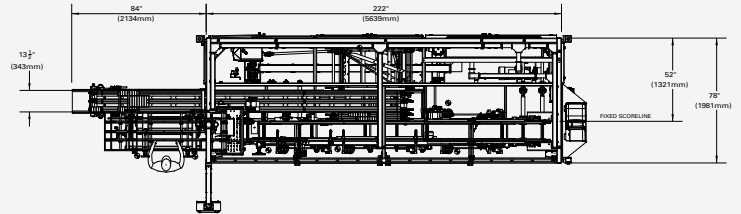

PLAN VIEW - SBBC

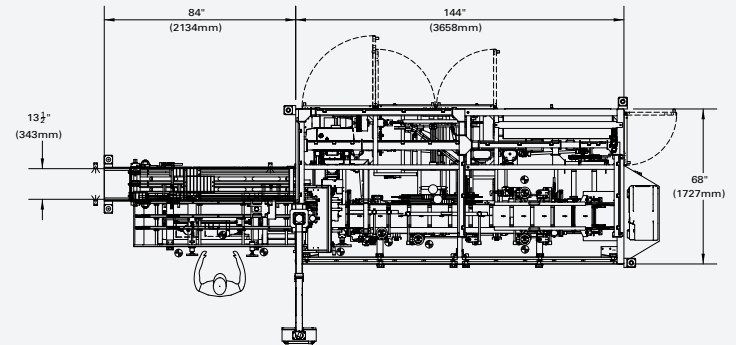

CARTON SIZE RANGE- BBC

Dimensions	(in)		(mm)	
	Min	Max	Min	Max
Length of Opening:	1.50	12.5*	38	320*
Width of Opening:	.75	4	20	100
Carton Depth:	4	12.50	100	318

* With 15 in. carton flight centers
 Not all minimums and maximums apply.
 Special modifications are available to extend the size range.

CARTON SIZE RANGE-SBBC

Dimensions	(in)		(mm)	
	Min	Max	Min	Max
Length of Opening:	1.50	7.5	38	190
Width of Opening:	.75	3	19	76
Carton Depth:	4	10	100	254

Not all minimums and maximums apply.
 Special modifications are available to extend the size range.

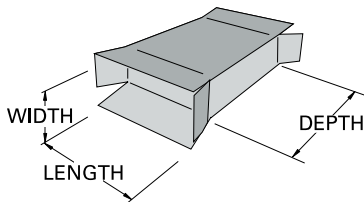

For more information on this product, scan the QR code with your mobile device.